

## Optional features

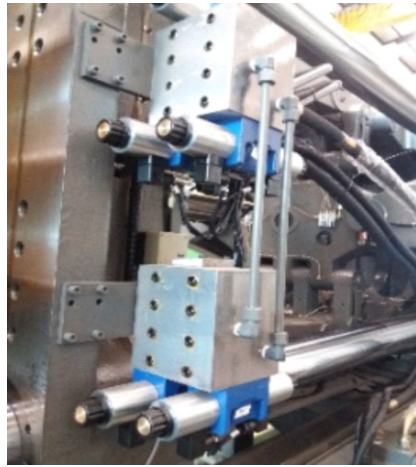

- Three sets or more of core pulls on the moving platen.

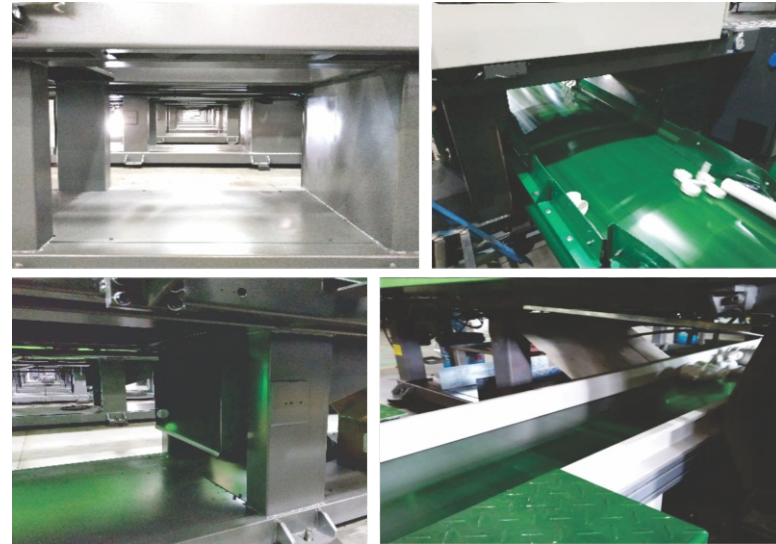

- Machine frame and product-drop area are risen and widened to ensure conveyor is properly aligned to connect the centralised product conveying and collection automated lines.



- PVC (380T and above) equipped with hopper slider.



- Adjustable guard door according to the factory layout and floor space.

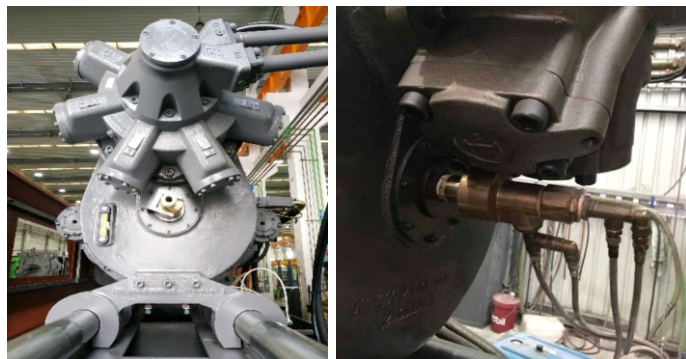

- Screw driven by gear box in high tonnage PVC machine is to ensure sufficient torque for plasticising.
- Oil cooling circuits run through the screw center for better control resin temperature to achieve the best plasticising.

# WELLTEC

## Specialist in PVC solutions



**PVC Injection Moulding Machine**  
**PVC-SEIII**  
**PVC-KII**  
**(60-1800Ton)**

# WELLTEC

## WELLTEC MACHINERY LTD.

10/F, Billion Plaza 2, No.10 Cheung Yue Street,  
Kowloon, Hong Kong  
Tel: + 852 2431 2198  
Fax: +852 2433 7060  
Website: [www.welltec.com.hk](http://www.welltec.com.hk)  
E-mail: [info@welltec.com.hk](mailto:info@welltec.com.hk)

Version: PVC-202106W



[www.welltec.com.hk](http://www.welltec.com.hk)

# Specialist in PVC solutions

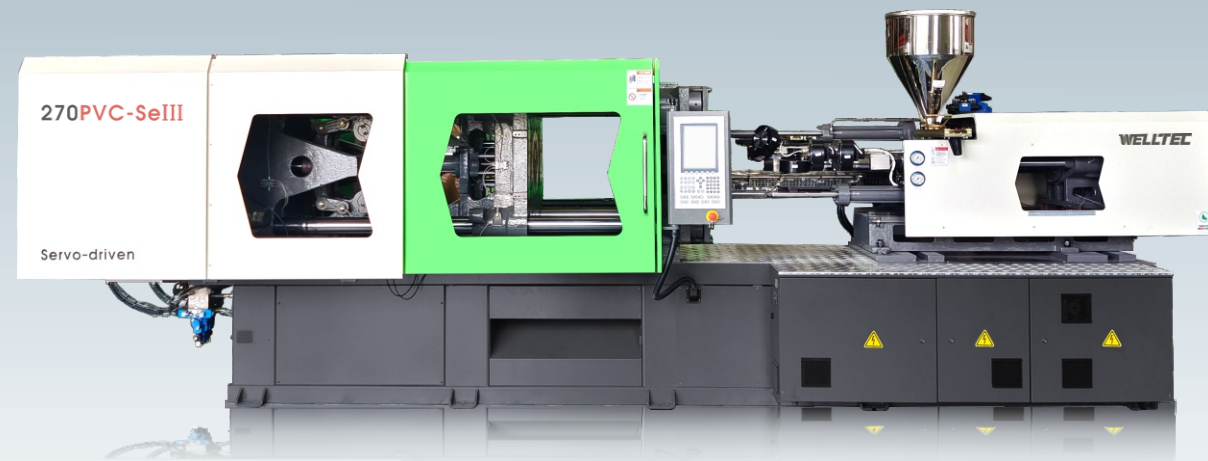

## Features

- At least 30% more energy saving than the traditional variable pump system .
- AC servo motor to achieve smooth motion even under low- speed.
- Higher products repeatability with the use of double- closed loop control of flow and pressure.
- Exceptional and stable performance under low pressure and low flow attained by the servo-driven hydraulic pumps.
- Ultra- strong corrosion resistance thanks to the special PVC screw that also enables excellent plasticising.
- Widened guarding between moulding area and movable door with two sets of core pulls to better suit a range of PVC products.

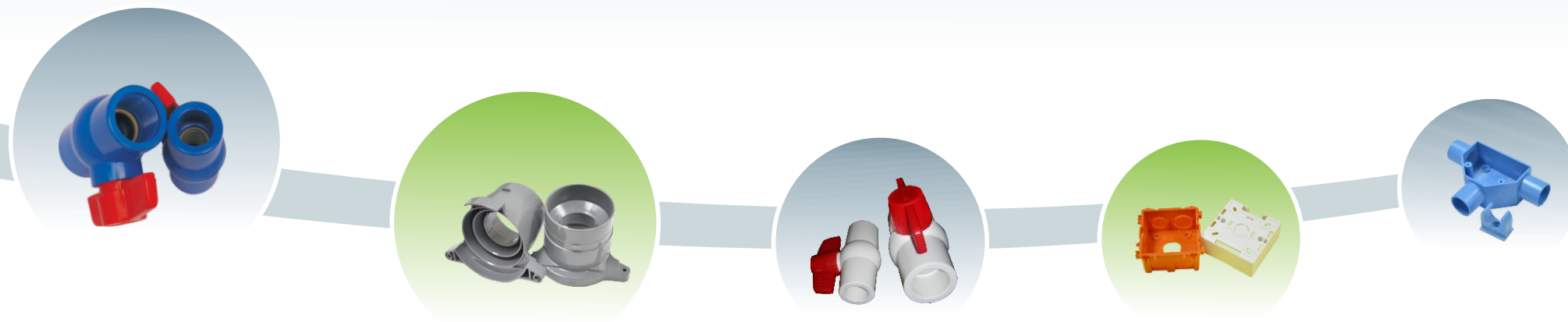



## Clamping Unit

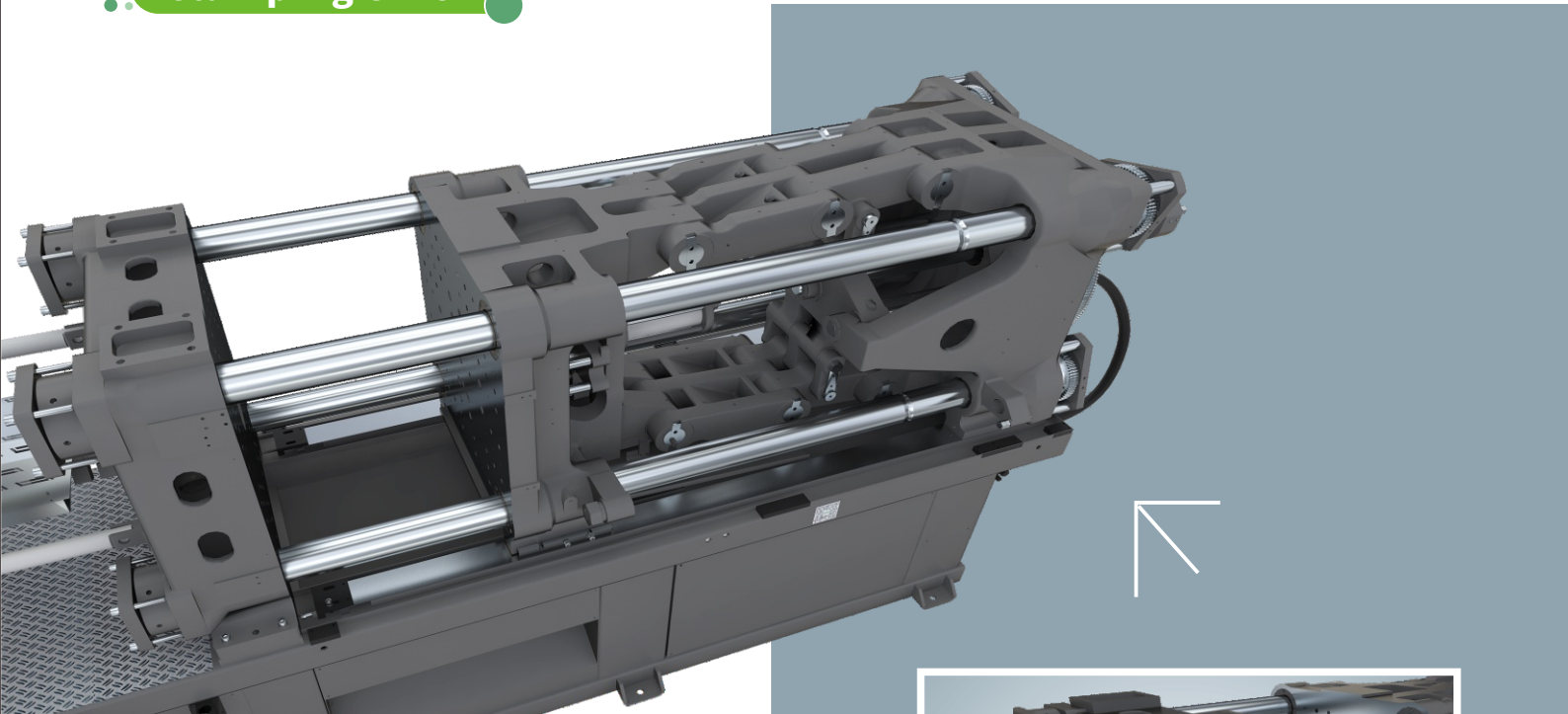

- Extra durability achieved through optimised clamping structure. High-rigidity machine frame minimises vibrations and supports smooth movements that satisfies heavy-duties production needs.

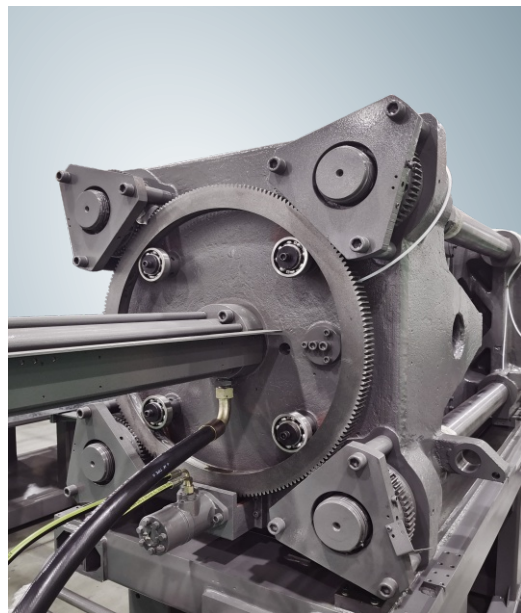

- High precision of mould height adjustment by gear to better protect the mould and improve production efficiency.

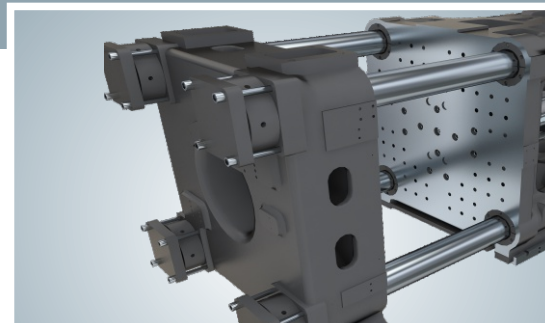

- Optimised platen designs to disperse stress and enhance product repeatability.

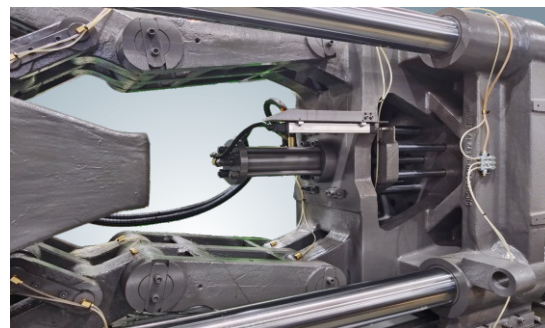

- Optimised toggle designs to ensure smooth platen movements and accurate stopping position.

## Injection Unit

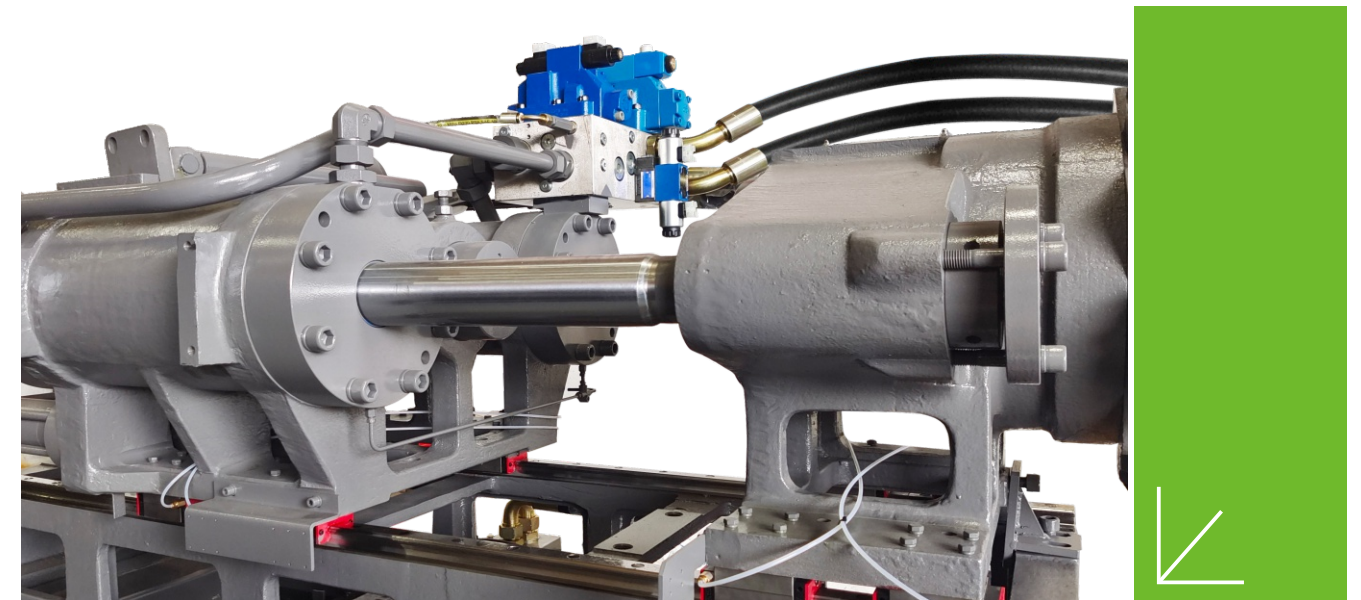

- High rigidity injection unit reduces deformation of carriage and cylinder rods. Spacing between screw and barrel is well maintained to avoid unilateral scratches and over shear-heating.
- Uniform plasticising and injection reduce products burns, oil seals damages and oil tank leaks.

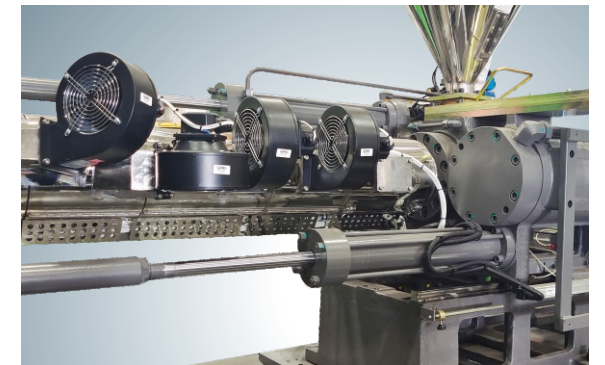

- Injection cylinders are diagonally positioned to effectively disperse stress.



- Linear guide rail realised high precision and low friction carriage movements which effectively lowered mechanical back pressure and overall energy consumption.



- High precision linear transducer ensures stable injection.



## Features of PVC Special

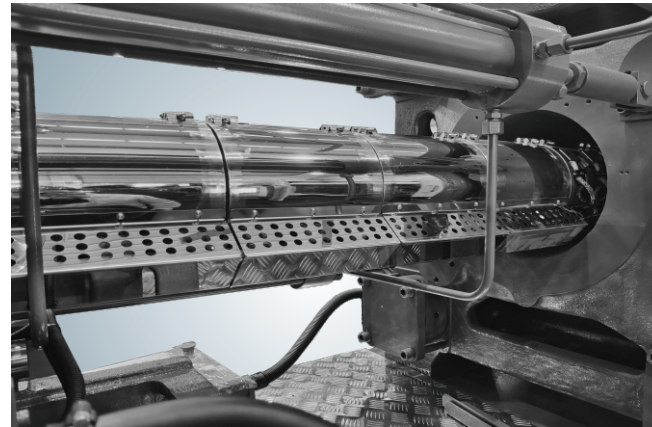

### Optimised air cooling and temperature control device

- Multiple PID controlled barrel fans to ensure accurate and stable temperature control. Speed-adjustable fans to balance the barrel temperature.
- Optimised barrel thickness is to ensure high heat retention. Thermocouples are properly positioned and probed based on the resin properties to maximise measurement accuracy. High power heater bands are to ensure adequate heating.



### Screw and tip set specialised for PVC

- Adopting chrome-plated screw and nozzle enables higher wear resistance. Special screw material and heat treatment process enables smooth material feeding.
- Screw designs (L/D ratio/compression ratio/three-section ratio) for different users and products to ensure excellent plasticising and smooth products surface.

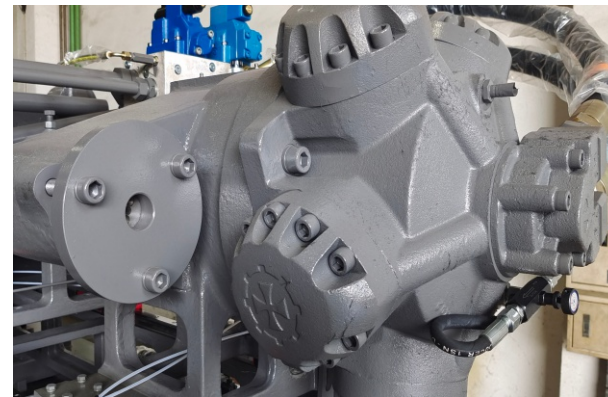

### Optimal arrangement of high efficiency plasticising motor

- Enlarged plasticising motor is to supply high torque for PVC being high viscosity and low mobility, to ensure stable plasticising.
- Further enlarged plasticising motor is available as an option to cope with CPVC resin being even more viscous and less mobile.

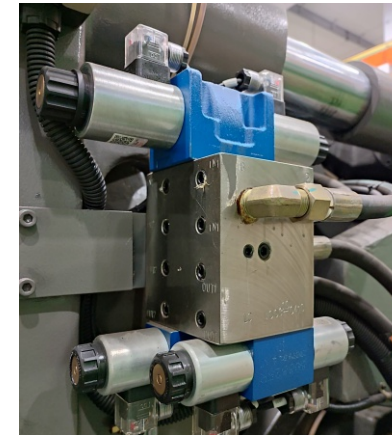

### Two sets of core pulls on the moving platen

- Standard two sets of core pulls to work with moulds for fittings.

### Abundant injection pressure

- Thickened injection cylinder and strengthened cylinder rod to ensure injection pressure is the same high level as in small diameter screw to enable PVC being injected by high pressure and low speed hydraulics.
- Wide range of injection parameter settings are to better protect the servo driver, motor and hydraulic pump and extend the lifespan of screw tip set.

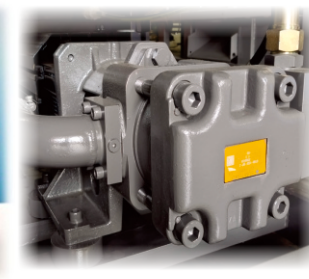

### Robust power pack

- Servo driver coupled gear pump to drive stronger system pressure. Excellent handlings for low pressure and low flow rate hydraulics.



### Widened guard door

- Widened guard doors at the clamping unit to accommodate extra-long core pulls for fitting moulds.



### Stainless steel hopper

- Convenient replacement of raw materials attained by movable hopper (for specific tonnage).
- Powder-collection tray is located below the hopper mounting for easy cleaning.



### Proportional back pressure

- Back pressure is accurately controlled by digital proportional valve to cope with PVC resin which is highly sensitive to shearing heat.



## SEIII control system



## KII control system



### Software & Functions

- High performance European B&R control system
- 10.4" TFT colour LCD display
- Users can identify the changes of parameter and source of changes
- Parameter data statistics for quality control
- Automatic control of temperature parameter by PID
- Mould parameter can be stored in USB devices and used in another injection moulding machine
- Remote monitoring of parameter and operation sequence by Modem or Ethernet
- Multi-language selection

- 8" TFT colour display
- User-friendly interface
- 4-stage injection. 4-stage holding pressure. 3-stage plasticising
- Pressure flow curve display
- Screw RPM display
- Barrel preheating function
- 100 sets of mould data

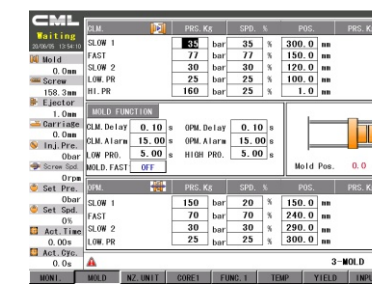
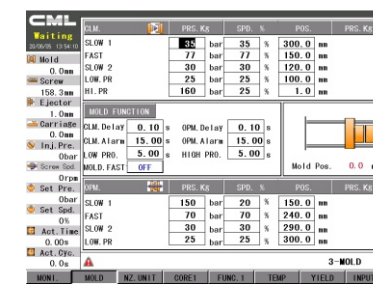
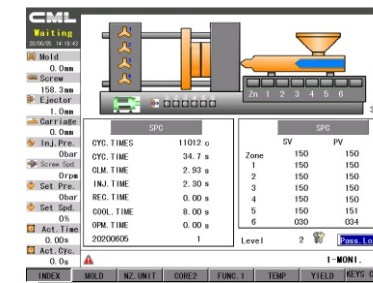
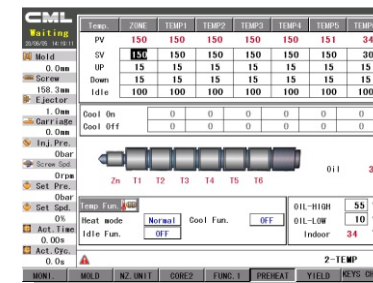
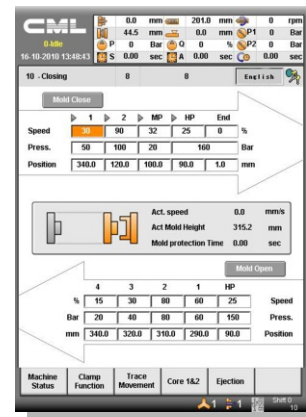
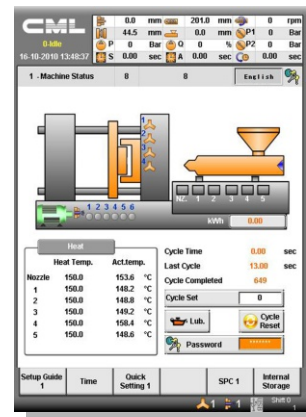

Facilitates real-time monitoring, remote diagnosis and smart factory management (optional)



PVC servo pump parameters

Item	Unit	70PVC-SeIII	100PVC-SeIII	140PVC-SeIII	170PVC-SeIII	210PVC-SeIII	270PVC-SeIII	330PVC-SeIII	420PVC-SeIII	480PVC-SeIII	520PVC-SeIII	560PVC-SeIII	660PVC-SeIII												
		700-312	1000-433	1400-630	1700-870	2100-1055	2700-1510	3300-1930	4200-2868	4800-3950	5200-3950	5600-5878	6600-5878												
<b>Injection Unit</b>																									
Screw diameter	mm	30	35	35	40	40	45	45	50	50	55	55	60	60	65	70	75	80	85	80	85	90	95	90	95
Theoretical shot volume	cc	124	168	192	251	283	358	398	491	491	594	713	848	919	1078	1443	1657	2011	2270	2011	2270	2799	3119	2799	3119
Shot weight (PVC)	g	148	202	231	302	339	429	477	589	589	713	855	1018	1103	1294	1732	1988	2413	2724	2413	2724	3359	3743	3359	3743
Shot weight (PVC)	oz	5.2	7.1	8.2	10.7	12.0	15.2	16.9	20.8	20.8	25.2	30.2	36.0	39.0	45.7	61.2	70.2	85.3	96.2	85.3	96.2	118.7	132.2	118.7	132.2
Injection pressure	MPa	254	186	225	172	223	176	219	177	215	178	211	178	210	179	199	173	197	174	197	174	210	188	210	188
Injection rate	cm <sup>3</sup> /sec	70	95	79	103	94	119	126	156	152	184	200	238	244	287	323	371	407	460	407	460	535	596	535	596
Injection stroke	mm	175		200		225		250		250		300		325		375		400		400		440		440	
Max. screwspeed	rpm	0-173		0-160		0-121		0-126		0-115		0-117		0-135		0-108		0-108		0-108		0-108		0-108	
Injection unit force	Ton	5.7		5.7		5.7		9.1		9.1		9.1		9.1		12		12		12		20.4		20.4	
Carriage stroke	mm	230		300		320		350		350		400		400		435		480		480		600		600	
<b>Clamping Unit</b>																									
Clamping force	Ton	70		100		140		170		210		270		330		420		480		520		560		660	
Max. daylight	mm	740		740		880		1000		1090		1210		1400		1530		1600		1700		1730		1830	
Clamping stroke	mm	360		360		430		480		540		600		700		780		780		850		880		910	
Distance between tie bars	mm	360x360		360x360		410x410		470x470		535x535		580x580		680x680		740x740		820x800		840x830		860x840		920x920	
Min. mould dimension	mm	250x250		250x250		280x280		320x320		370x370		400x400		470x470		520x520		570x560		580x580		600x590		645x645	
Mould thickness range	mm	120- 380		120- 380		145- 450		150- 520		175- 550		195- 610		250- 700		250- 750		300- 820		300- 850		350-850		350-920	
Ejector force	Ton	4.1		4.1		4.1		7.7		9.9		11.1		11.1		16.6		16.6		16.6		16.6		16.6	
Ejector stroke	mm	100		100		120		160		170		195		200		210		240		240		240		290	
No. of ejector pins	unit	5		5		5		5		9		13		13		13		17		17		17		21	
<b>Power Unit</b>																									
Max. motor power	kW	11.8		11.8		13.4		16.4		16.4		20.5		26.7		40.9		50.7		50.7		67.1		67.1	
System pressure	MPa	17.5		17.5		17.5		17.5		17.5		17.5		17.5		17.5		17.5		17.5		17.5		17.5	
Hydraulic pump capacity	L/min	61		61		72		95		112.5		145		176		220		275		275		385		385	
No. of heating zones	unit	3+1		3+1		4+1		4+1		4+1		5+1		5+1		5+1		5+1		5+1		5+1		5+1	
Heating power	kW	7.2		9		10.81		14.03		16		18.7		22		28.95		35.85		35.85		39.7		39.7	
Total power	kW	20		21.8		25.21		31.43		33.4		40.2		49.7		70.85		87.55		87.55		107.8		107.8	
Total current	A	27.3		29.8		34.5		43.0		45.7		55.0		68.0		96.9		119.7		119.7		131.0		131.0	
<b>General</b>																									
Machine net weight	Ton	3.27		3.6		4.5		6		7.1		8.55		11.52		14.68		17		19		23		26	
Oil filling capacity	L	200		200		200		320		360		480		550		700		700		700		1000		1000	

We are always working on improvement and reserve the rights to change design and specifications without prior notice

Machine Dimensions

【 70 330PVC-SeIII 】

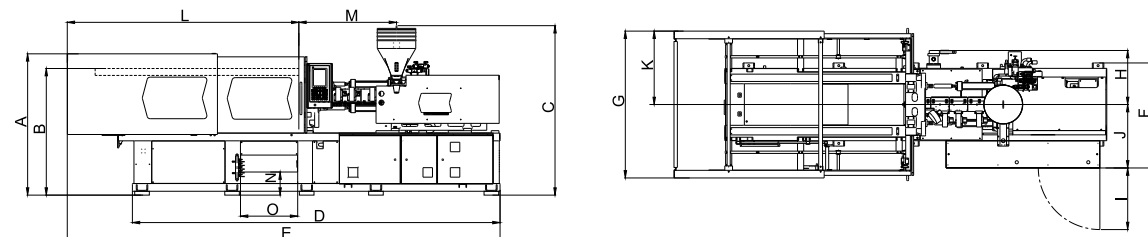

Model	A	B	C	D	E	F	G	H	I	J	K	L	M	N	O
70PVC-SeIII	1619	1400	2062	3560	4220	1054	1542	587	800	634	771	2177	852	330	580
100PVC-SeIII	1619	1400	2062	3560	4220	1054	1542	587	800	634	771	2177	980	330	580
140PVC-SeIII	1673	1486	2098	3878	4764	1291	1638	623	800	668	819	2468	1042	300	613
170PVC-SeIII	1762	1567	2161	4513	5252	1284	1737	658	800	789	869	2729	1487	300	680
210PVC-SeIII	1835	1645	2200	4778	5625	1364	1907	702	800	824	954	3009	1269	300	743
270PVC-SeIII	1961	1757	2398	5125	6048	1414	2002	781	800	849	1001	3248	1370	300	848
330PVC-SeIII	2078	1884	2284	5575	6531	1514	2137	805	800	899	1069	3649	1494	320	910

【 420 660PVC-SeIII 】

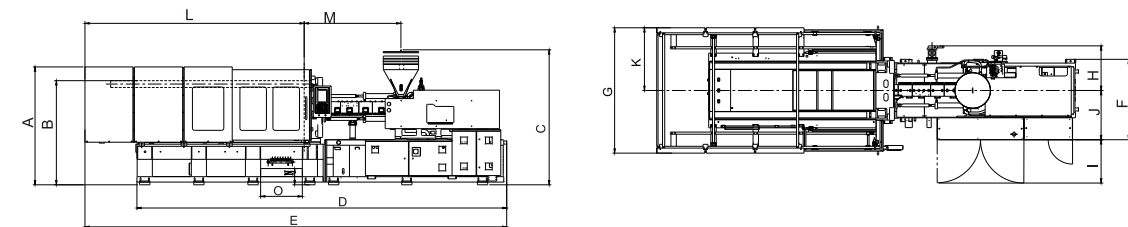

Model	A	B	C	D	E	F	G	H	I	J	K	L	M	N	O
420PVC-SeIII	2176	1923	2493	6831	7791	1484	2314	823	800	909	1157	4050	1730	(300)	770
480PVC-SeIII	2246	1987	2526	7061	8025	1549	2428	856	800	942	1214	4249	2012	(300)	825
520PVC-SeIII	2244	2005	2526	7196	8249.5	1549	2450	856	800	942	1225	4474	2012	(300)	890
560PVC-SeIII	2223	2085	2537	7589	8849	2194	2491	1234	850	960	1245	4405	2094	(300)	690
660PVC-SeIII	2402	2125	2537	7729	9103	2194	2644	1234	850	960	1322	4690	2094	(300)	700

Remark: C-hopper height for reference only



Platen/Nozzle Dimensions

70PVC-SeIII

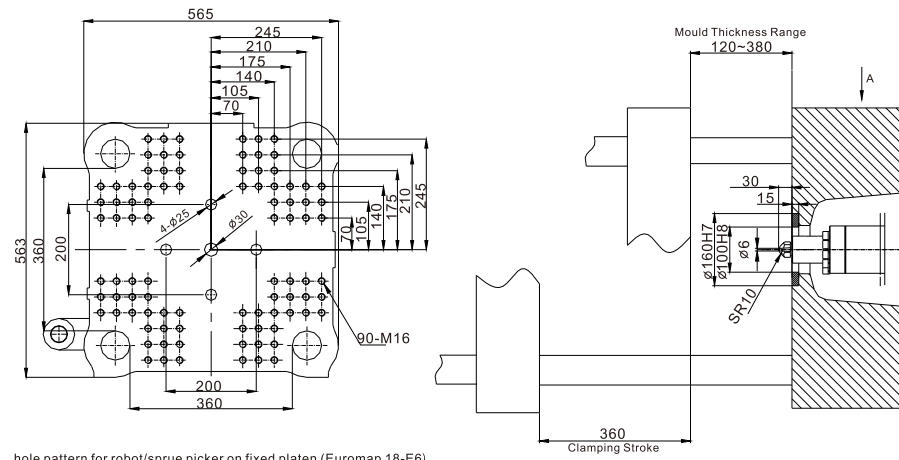

hole pattern for robot/sprue picker on fixed platen (Euomap 18-E6)

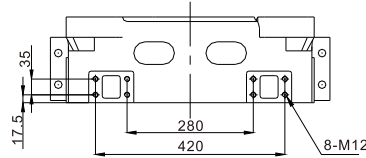

100PVC-SeIII

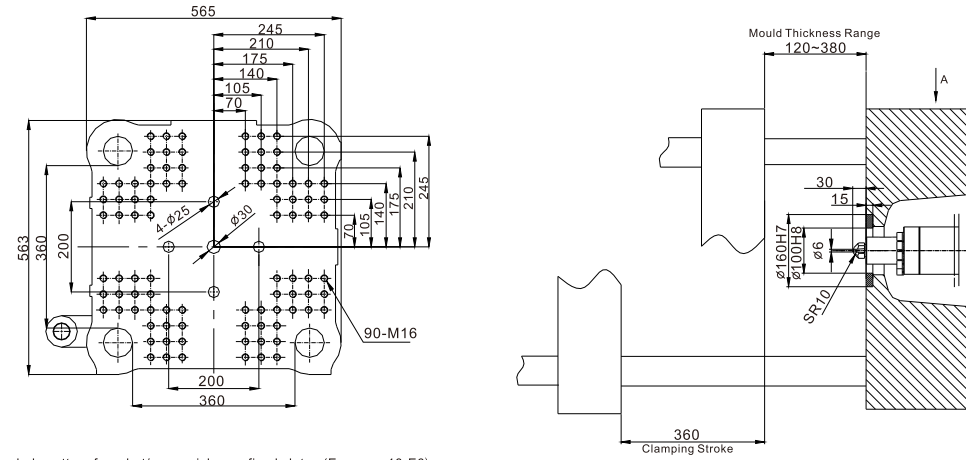

hole pattern for robot/sprue picker on fixed platen (Euomap 18-E6)

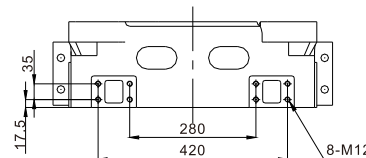

140PVC-SeIII

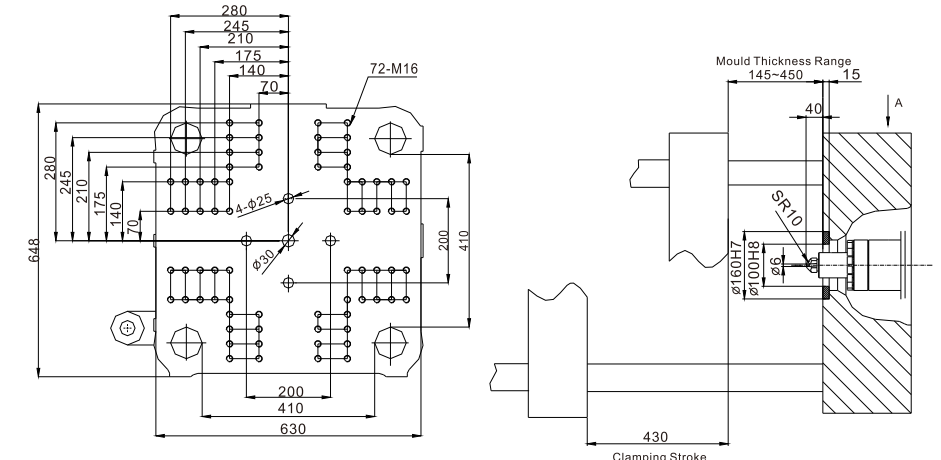

hole pattern for robot/sprue picker on fixed platen (Euomap 18-E7)

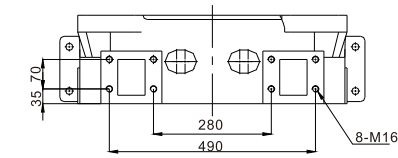

170PVC-SeIII

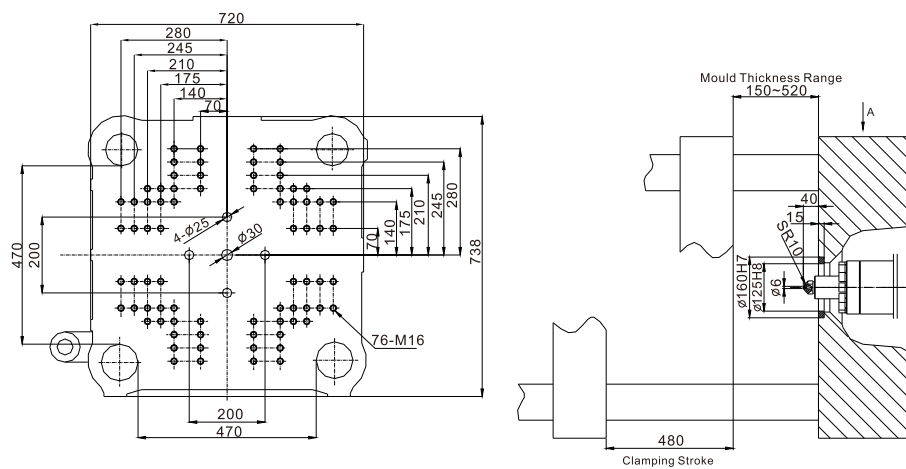

hole pattern for robot/sprue picker on fixed platen (Euomap 18-E8)

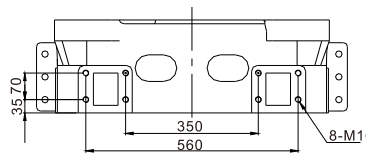

210PVC-SeIII

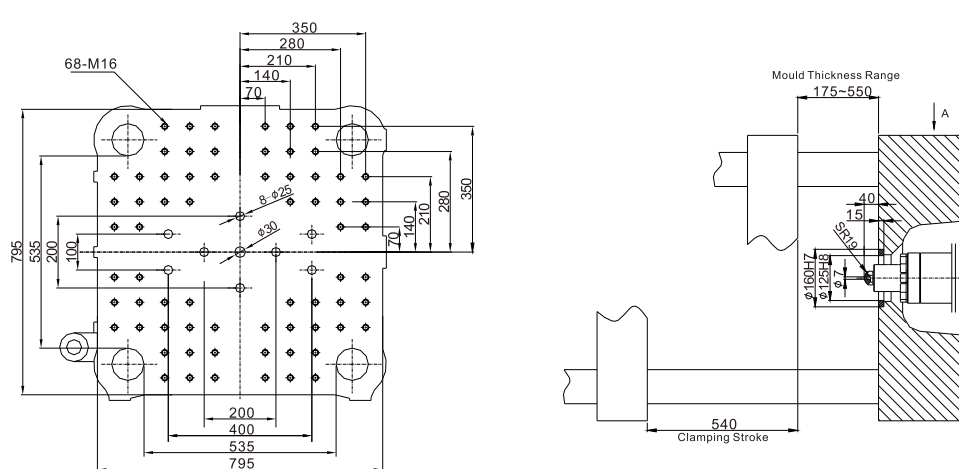

hole pattern for robot/sprue picker on fixed platen (Euomap 18-E9)

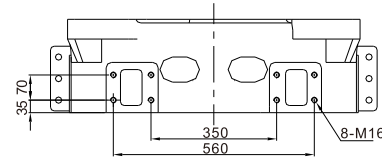

270PVC-SeIII

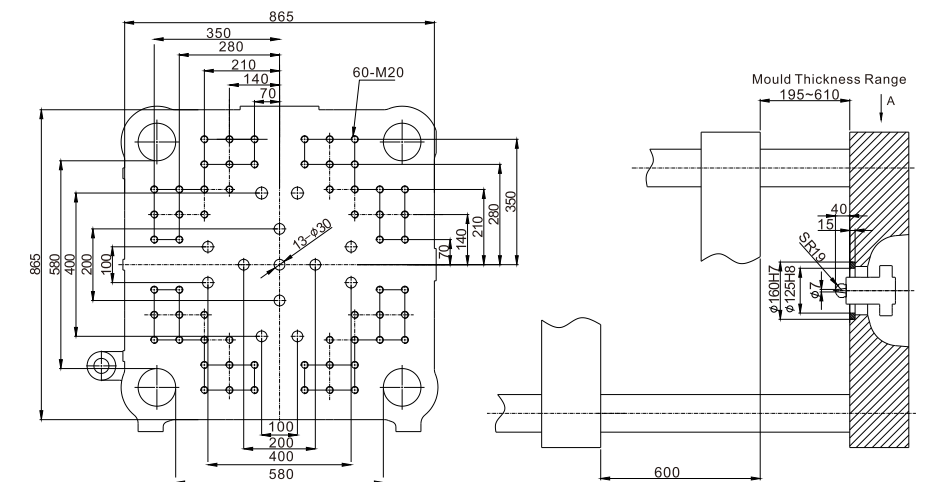

hole pattern for robot/sprue picker on fixed platen (Euomap 18-E10)

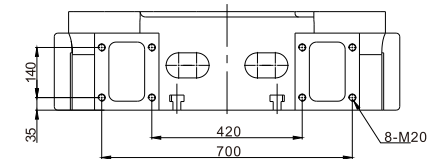



Platen/Nozzle Dimensions

330PVC-SeIII

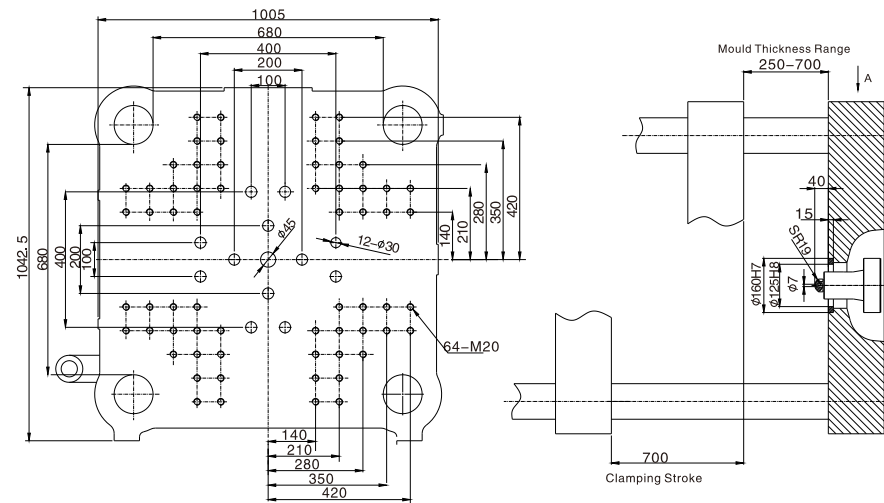

hole pattern for robot/sprue picker on fixed platen (Euromap 18-E11)

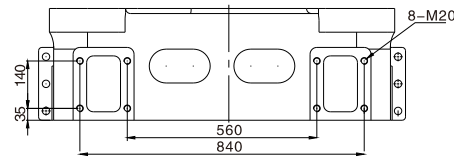

420PVC-SeIII

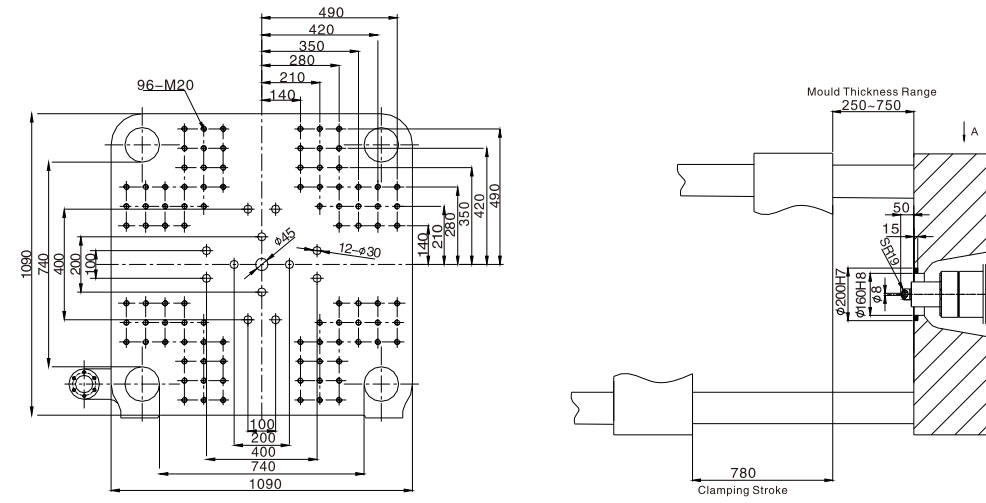

hole pattern for robot/sprue picker on fixed platen (Euromap 18-E12)

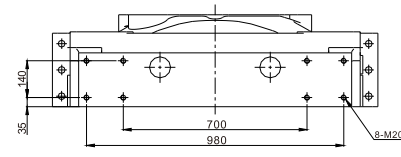

480PVC-SeIII

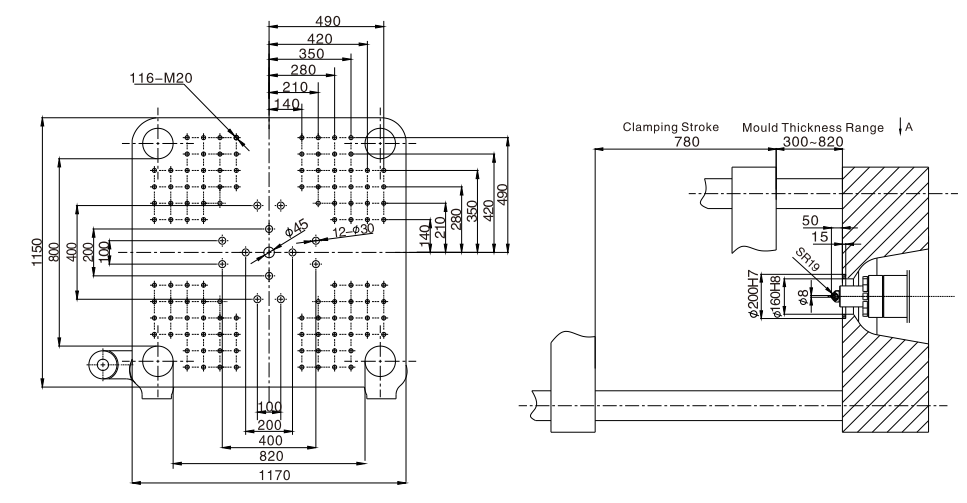

hole pattern for robot/sprue picker on fixed platen (Euromap 18-E13)

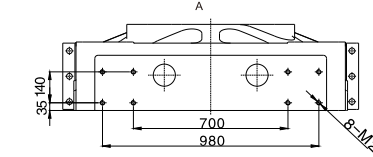

520PVC-SeIII

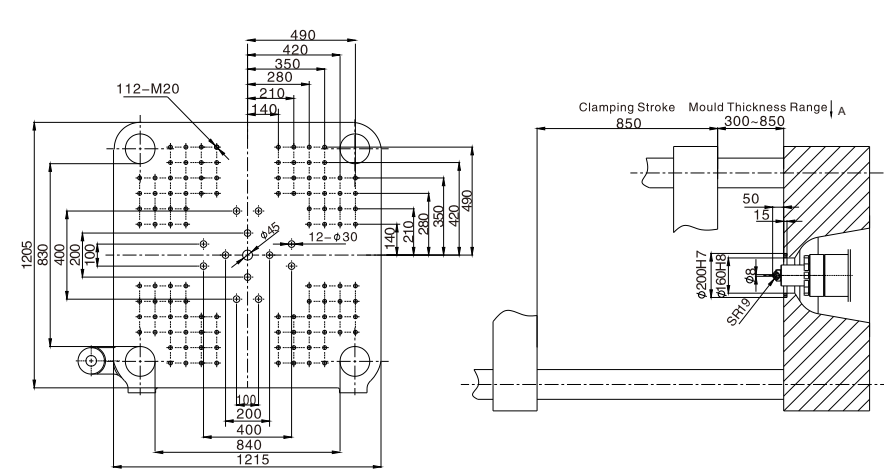

hole pattern for robot/sprue picker on fixed platen (Euromap 18-E13)

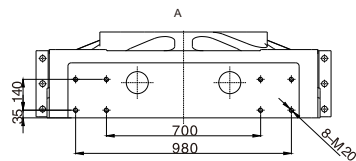

560PVC-SeIII

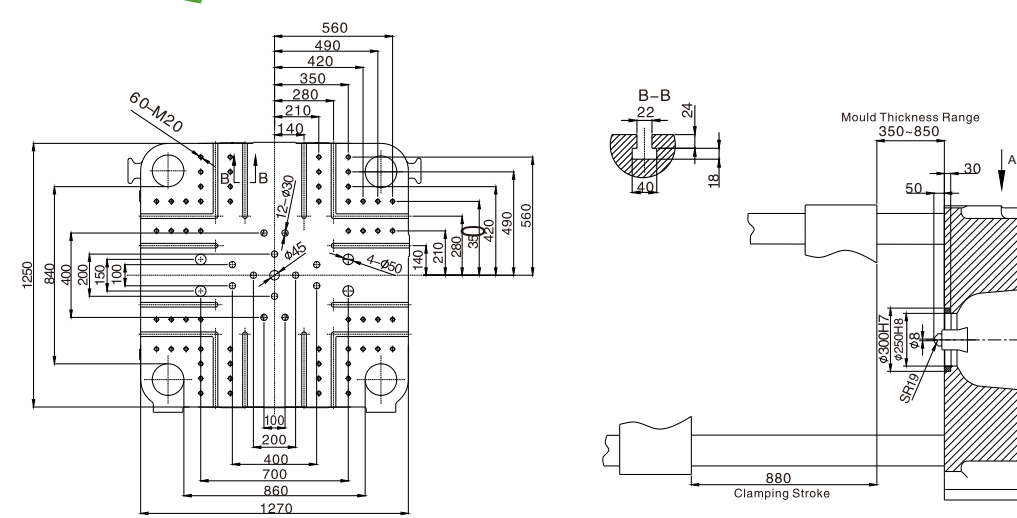

hole pattern for robot/sprue picker on fixed platen (Euromap 18-E13)

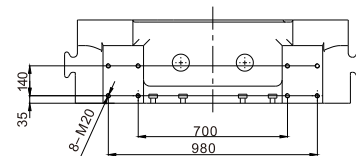

660PVC-SeIII

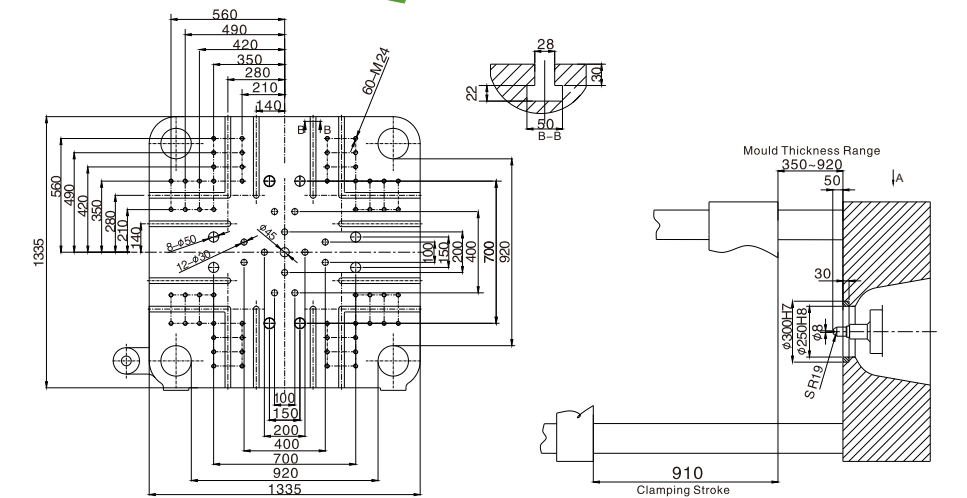

hole pattern for robot/sprue picker on fixed platen (Euromap 18-E15)

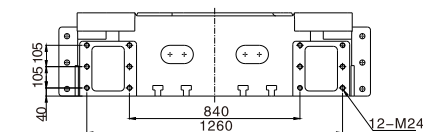



PVC servo pump parameters

Item	Unit	60PVC-KII	90PVC-KII	130PVC-KII	160PVC-KII	190PVC-KII	260PVC-KII	320PVC-KII	380PVC-KII	450PVC-KII	500PVC-KII	560PVC-KII	660PVC-KII												
		600-312	900-433	1300-630	1600-870	1900-1055	2600-1510	3200-1930	3800-2868	4500-3950	5000-3950	5600-5878	6600-5878												
<b>Injection Unit</b>																									
Screw diameter	mm	30	35	35	40	40	45	45	50	50	55	55	60	60	65	70	75	80	85	80	85	90	95	90	95
Theoretical shot volume	cc	124	168	192	251	283	358	398	491	491	594	713	848	919	1078	1443	1657	2011	2270	2011	2270	2799	3119	2799	3119
Shot weight (PVC)	g	148	202	231	302	339	429	477	589	589	713	855	1018	1103	1294	1732	1988	2413	2724	2413	2724	3359	3743	3359	3743
Shot weight (PVC)	oz	5.2	7.1	8.2	10.7	12.0	15.2	16.9	20.8	20.8	25.2	30.2	36.0	39.0	45.7	61.2	70.2	85.3	96.2	85.3	96.2	118.7	132.2	118.7	132.2
Injection pressure	MPa	254	186	225	172	223	176	219	177	215	178	211	178	210	179	199	173	197	174	197	174	210	188	210	188
Injection rate	cm <sup>3</sup> /sec	70	95	79	103	94	119	126	156	152	184	191	228	244	287	323	371	407	460	407	460	489	545	489	545
Injection stroke	mm	175	200	225	250	250	300	325	375	400	440	300	325	375	400	400	400	400	400	400	400	440	440	440	440
Max. screwspeed	rpm	0-173	0-160	0-121	0-126	0-115	0-112	0-135	0-108	0-108	0-99	0-112	0-135	0-108	0-108	0-108	0-108	0-108	0-108	0-108	0-108	0-99	0-99	0-99	0-99
Injection unit force	Ton	5.7	5.7	5.7	9.1	9.1	9.1	9.1	12	12	20.4	9.1	9.1	12	12	12	12	12	12	12	12	20.4	20.4	20.4	20.4
Carriage stroke	mm	230	300	320	350	350	400	400	435	480	600	400	400	435	480	480	480	480	480	480	480	600	600	600	600
<b>Clamping Unit</b>																									
Clamping force	Ton	60	90	130	160	190	260	320	380	450	500	260	320	380	450	500	500	500	500	500	500	560	660	660	660
Max. daylight	mm	680	680	820	906	1000	1130	1275	1450	1560	1700	1130	1275	1450	1560	1560	1560	1560	1560	1560	1560	1730	1830	1830	1830
Clamping stroke	mm	320	320	410	446	490	550	615	710	740	850	550	615	710	740	740	740	740	740	740	740	880	910	910	910
Distance between tie bars	mm	360x360	360x360	410x410	460x460	510x510	580x580	660x660	740x740	780x780	840x830	580x580	660x660	740x740	780x780	780x780	780x780	780x780	780x780	780x780	780x780	840x830	860x840	920x920	920x920
Min. mould dimension	mm	250x250	250x250	280x280	320x320	350x350	400x400	460x460	510x510	540x540	580x580	400x400	460x460	510x510	540x540	540x540	540x540	540x540	540x540	540x540	540x540	600x590	645x645	645x645	645x645
Mould thickness range	mm	150-360	150-360	150-410	150-460	175-510	200-580	250-660	250-740	300-820	300-850	200-580	250-660	250-740	300-820	300-820	300-820	300-820	300-820	300-820	300-820	350-850	350-850	350-920	350-920
Ejector force	Ton	4	4	4.2	4.9	4.9	6.7	6.7	11.1	13.7	16.6	6.7	6.7	11.1	13.7	13.7	13.7	13.7	13.7	13.7	16.6	16.6	16.6	16.6	
Ejector stroke	mm	85	85	100	130	140	160	180	200	250	240	160	180	200	250	250	250	250	250	250	250	240	240	290	290
No. of ejector pins	unit	5	5	5	5	5	9	13	13	13	17	9	13	13	13	13	13	13	13	13	17	17	21	21	
<b>Power Unit</b>																									
Max. motor power	kW	11.8	11.8	15.7	17.3	23	31.4	32	46.1	56.5	56.5	31.4	32	46.1	56.5	56.5	56.5	56.5	56.5	56.5	56.5	73.3	73.3	73.3	73.3
System pressure	MPa	17.5	17.5	17.5	17.5	17.5	17.5	17.5	17.5	17.5	17.5	17.5	17.5	17.5	17.5	17.5	17.5	17.5	17.5	17.5	17.5	17.5	17.5	17.5	17.5
Hydraulic pump capacity	L/min	61	61	72	95	112.5	139	176	220	275	275	139	176	220	275	275	275	275	275	275	275	352	352	352	352
No. of heating zones	unit	3+1	3+1	4+1	4+1	4+1	5+1	5+1	5+1	5+1	5+1	5+1	5+1	5+1	5+1	5+1	5+1	5+1	5+1	5+1	5+1	5+1	5+1	5+1	5+1
Heating power	kW	7.2	9	10.81	14.03	16	18.7	22	28.95	35.85	35.85	18.7	22	28.95	35.85	35.85	35.85	35.85	35.85	35.85	39.7	39.7	39.7	39.7	
Total power	kW	20	21.8	27.51	32.33	40	51.1	55	76.05	93.35	93.35	51.1	55	76.05	93.35	93.35	93.35	93.35	93.35	93.35	114.0	114.0	114.0	114.0	
Total current	A	27.3	29.8	37.6	44.2	54.7	69.9	75.2	104.0	127.7	127.7	69.9	75.2	104.0	127.7	127.7	127.7	127.7	127.7	127.7	155.9	155.9	155.9	155.9	
<b>General</b>																									
Machine net weight	Ton	3.25	3.25	4.2	5.2	6.1	7.64	10.5	14.1	16.7	19	7.64	10.5	14.1	16.7	16.7	16.7	16.7	16.7	16.7	19	23	26	26	
Oil filling capacity	L	140	140	160	220	260	350	470	490	600	600	350	470	490	600	600	600	600	600	600	600	1000	1000	1000	1000

We are always working on improvement and reserve the rights to change design and specifications without prior notice

Machine Dimensions

【 60~320PVC-KII 】

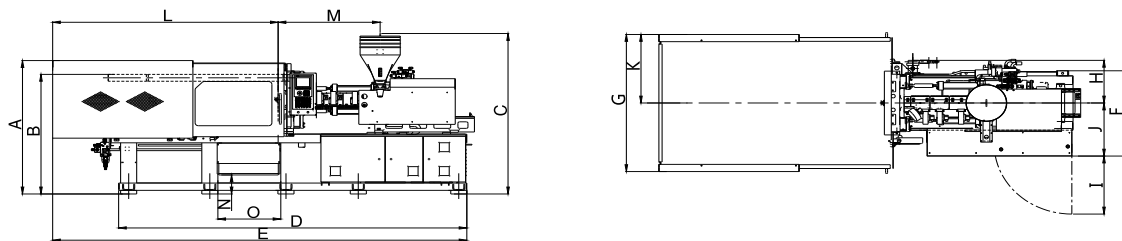

Model	A	B	C	D	E	F	G	H	I	J	K	L	M	N	O
60PVC-KII	1574	1410	2070	3340	3870	842	1375	505	800	557	695	2015	846	380	613
90PVC-KII	1574	1410	2070	3340	3870	842	1375	506	800	557	695	2015	972	380	613
130PVC-KII	1670	1502	2123	3665	4383	1146	1460	544	800	602	725	2375	1043	321	635
160PVC-KII	1777	1596	2195	4015	4772	1271	1726	564	800	707	863	2585	1187	297	694
190PVC-KII	1840	1650	2214	4332	5152	1177	1892	589	800	732	946	2805	1269	261	783
260PVC-KII	1914	1722	2248	4855	5764	674	1828	674	800	792	914	3009	1369	221	905
320PVC-KII	2051	1917	2360	5211	5212	751	2160	751	800	871	1080	3315	1494	259	1109

【 380~660PVC-KII 】

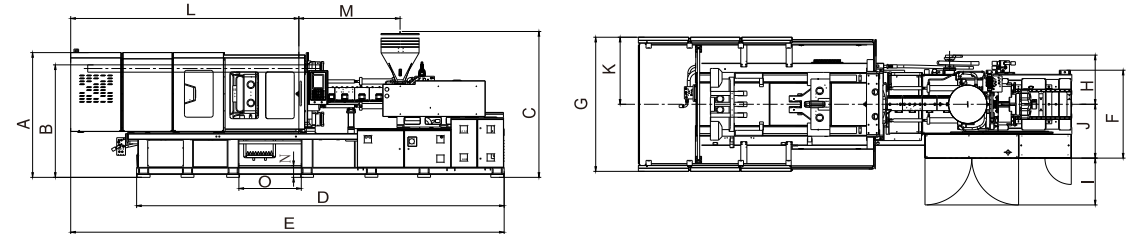

Model	A	B	C	D	E	F	G	H	I	J	K	L	M	N	O
380PVC-KII	2192	2133	2381	6284	7410	1499	2292	893	800	915	1145	3900	1730	(300)	1015
450PVC-KII	2244	1975	2415	6670	7821	1549	2638	906	800	941	1319	4099	2012	(300)	1014
500PVC-KII	2195	1988	2415	6752	8155	1549	2469	906	800	941	1234	4423	2012	(300)	690
560PVC-KII	2223	2085	2537	7589	8849	2194	2491	1234	850	960	1245	4405	2094	(300)	690
660PVC-KII	2402	2125	2537	7729	9103	2194	2644	1234	850	960	1322	4690	2094	(300)	700

Remark: C-hopper height for reference only

Platen/Nozzle Dimensions

60PVC-KII

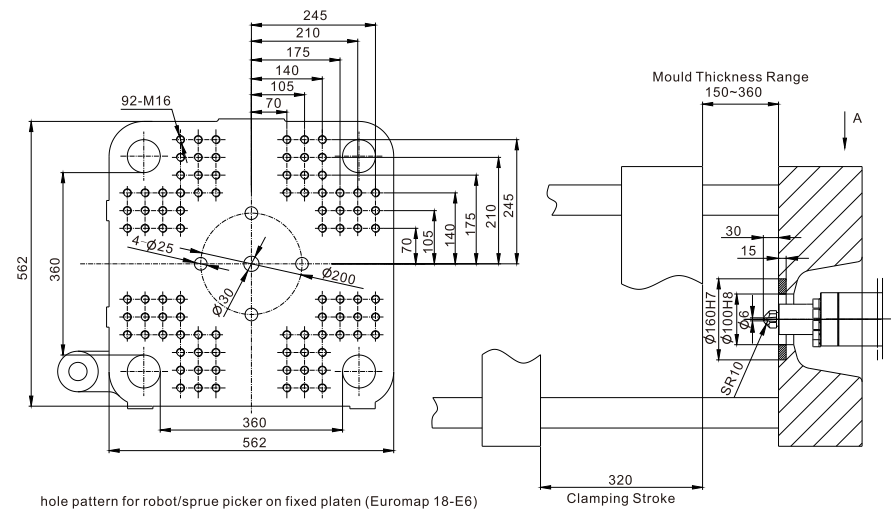

hole pattern for robot/sprue picker on fixed platen (Euromap 18-E6)

Clamping Stroke

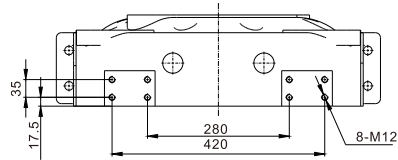

90PVC-KII

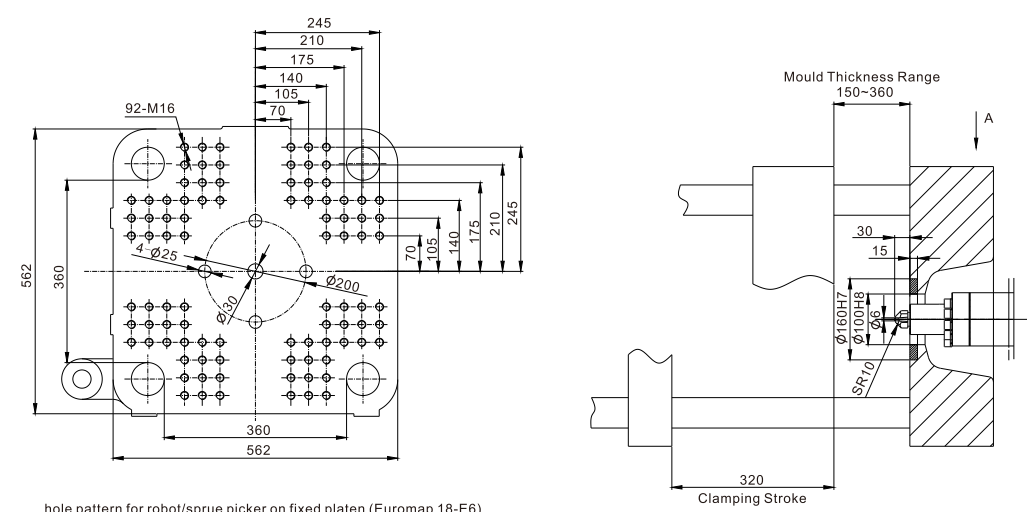

hole pattern for robot/sprue picker on fixed platen (Euromap 18-E6)

Clamping Stroke

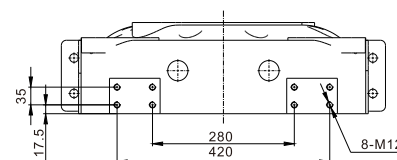

130PVC-KII

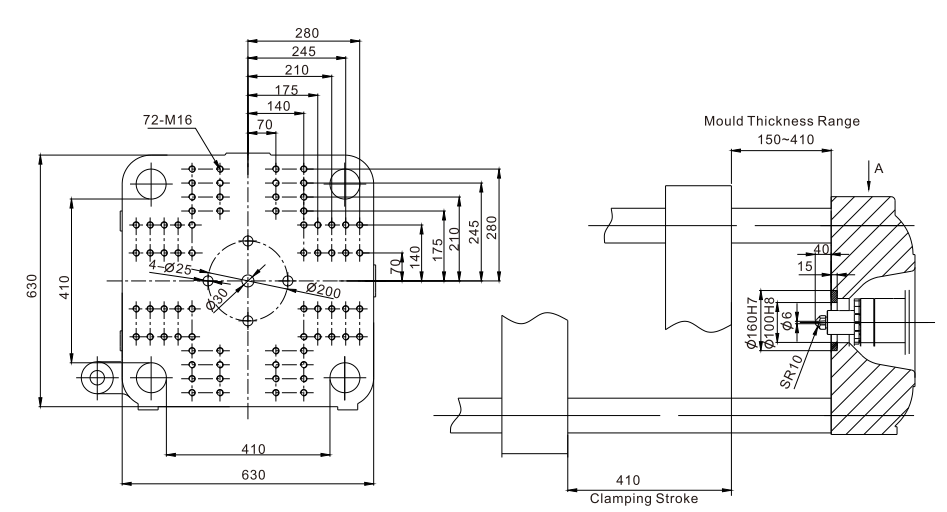

hole pattern for robot/sprue picker on fixed platen (Euromap 18-E7)

Clamping Stroke

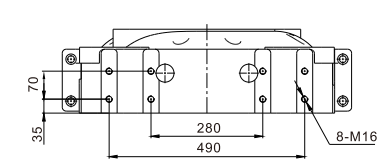

160PVC-KII

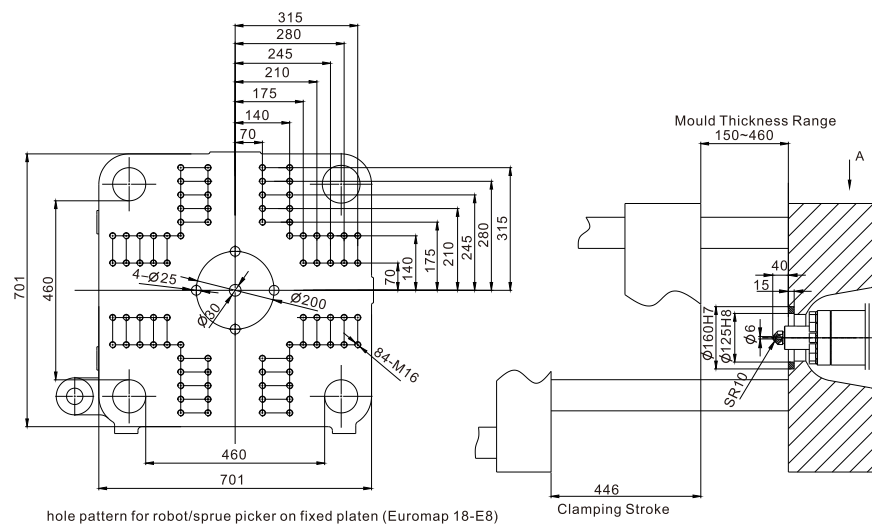

hole pattern for robot/sprue picker on fixed platen (Euromap 18-E8)

Clamping Stroke

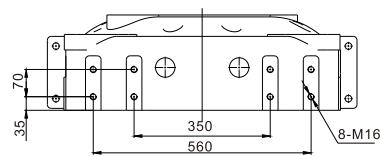

190PVC-KII

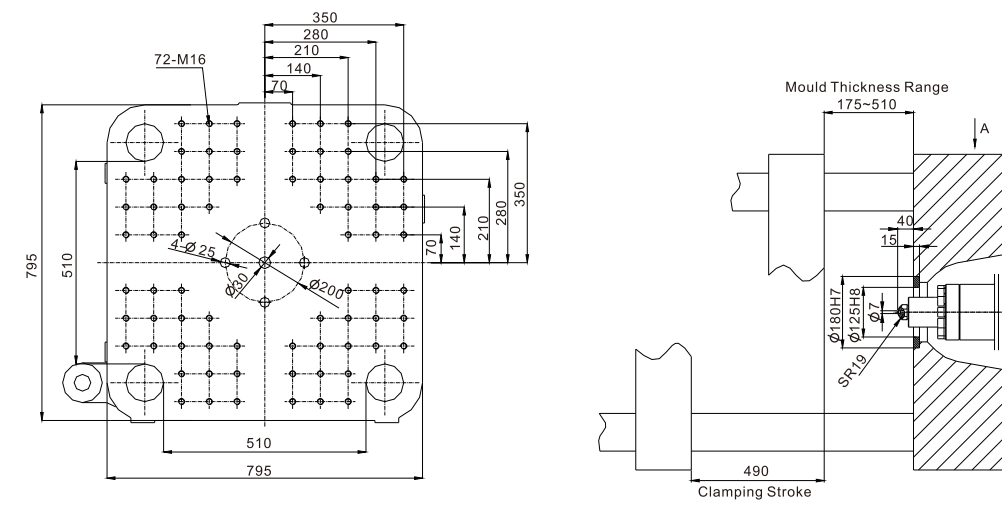

hole pattern for robot/sprue picker on fixed platen (Euromap 18-E9)

Clamping Stroke

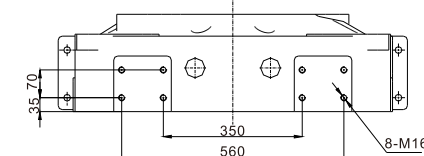

260PVC-KII

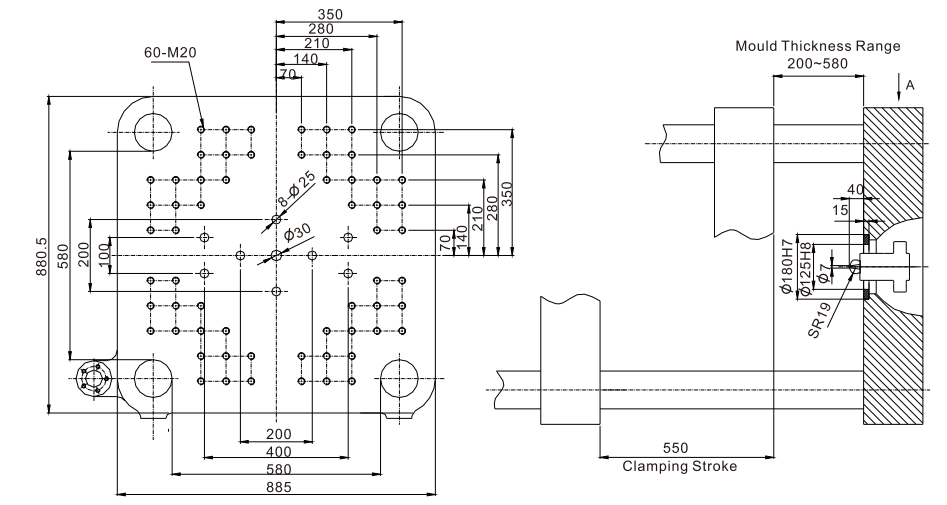

hole pattern for robot/sprue picker on fixed platen (Euromap 18-E10)

Clamping Stroke

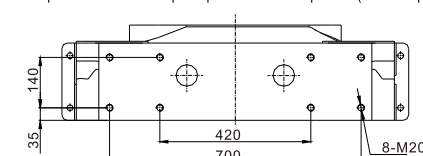



Platen/Nozzle Dimensions

320PVC-KII

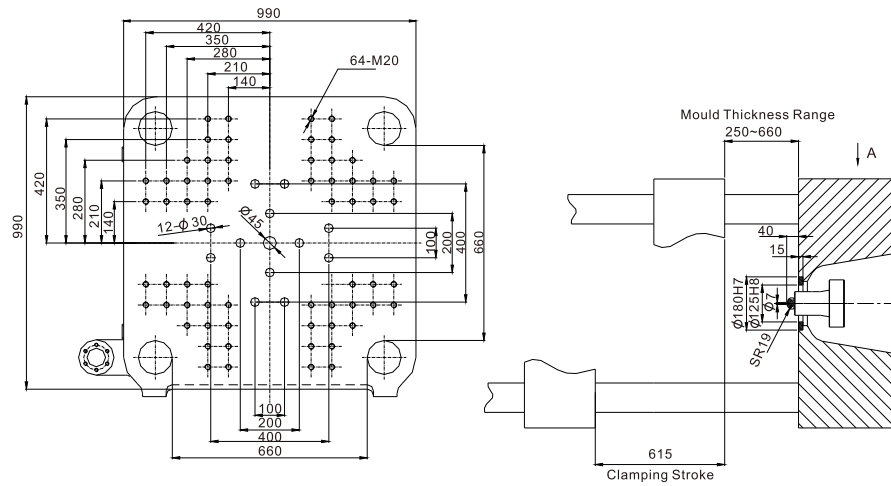

hole pattern for robot/sprue picker on fixed platen (Euomap 18-E11)

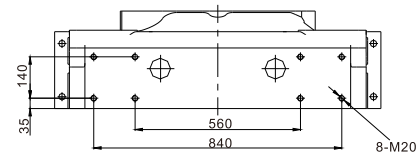

380PVC-KII

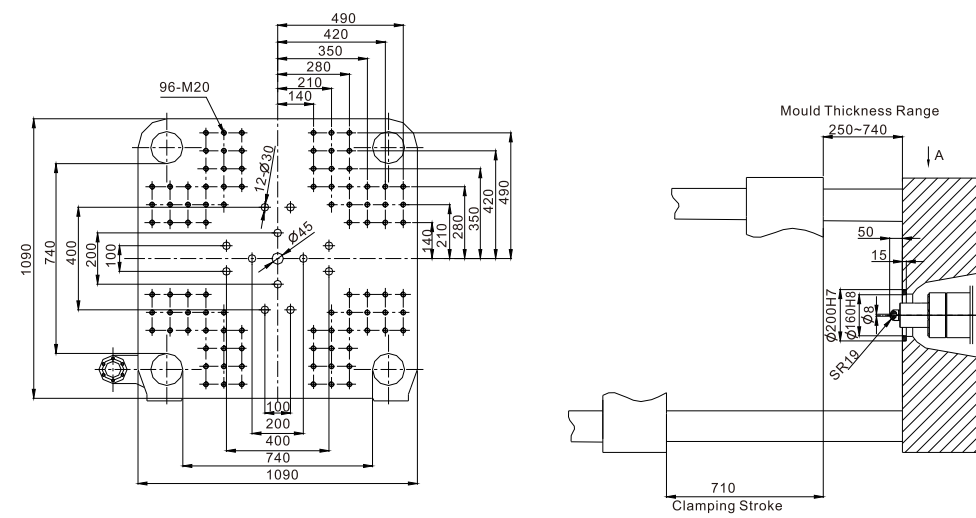

hole pattern for robot/sprue picker on fixed platen (Euomap 18-E12)

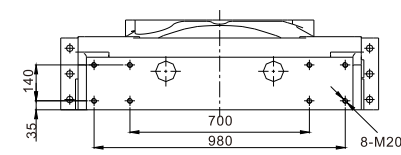

450PVC-KII

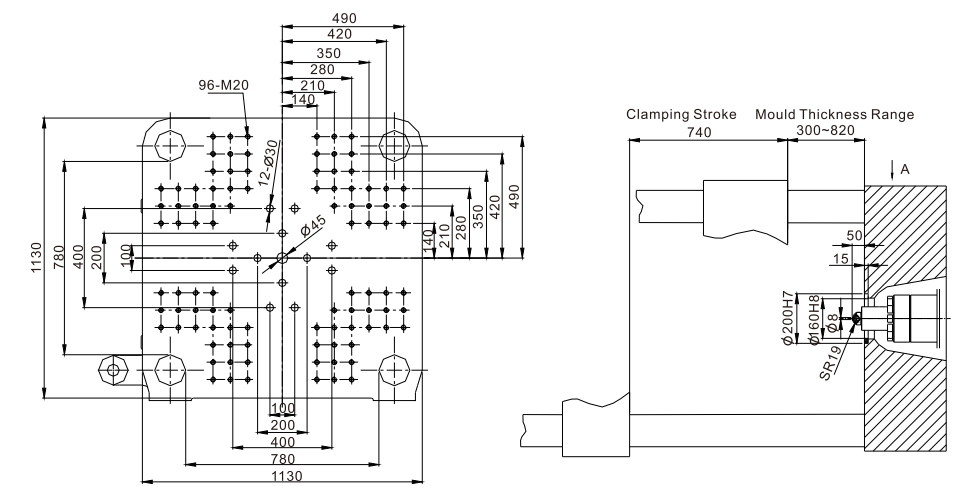

hole pattern for robot/sprue picker on fixed platen (Euomap 18-E13)

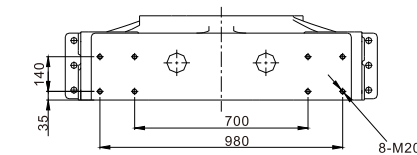

500PVC-KII

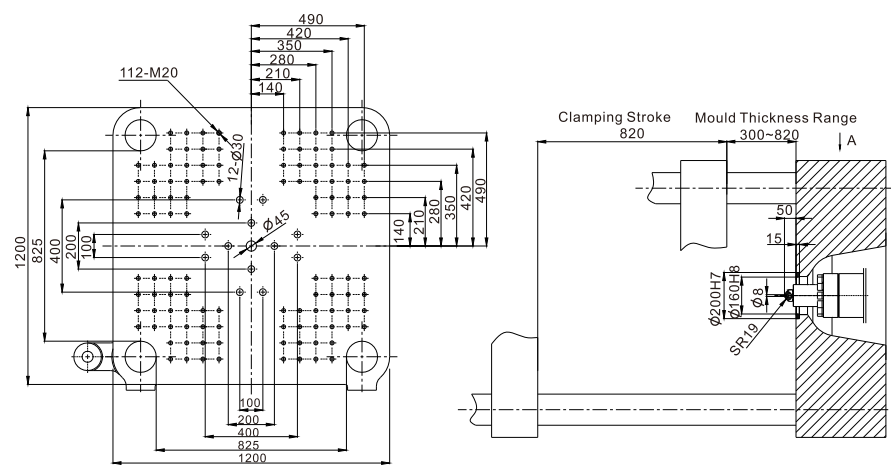

hole pattern for robot/sprue picker on fixed platen (Euomap 18-E13)

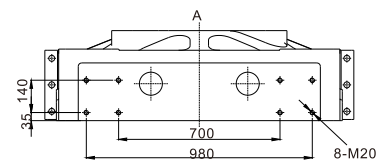

560PVC-KII

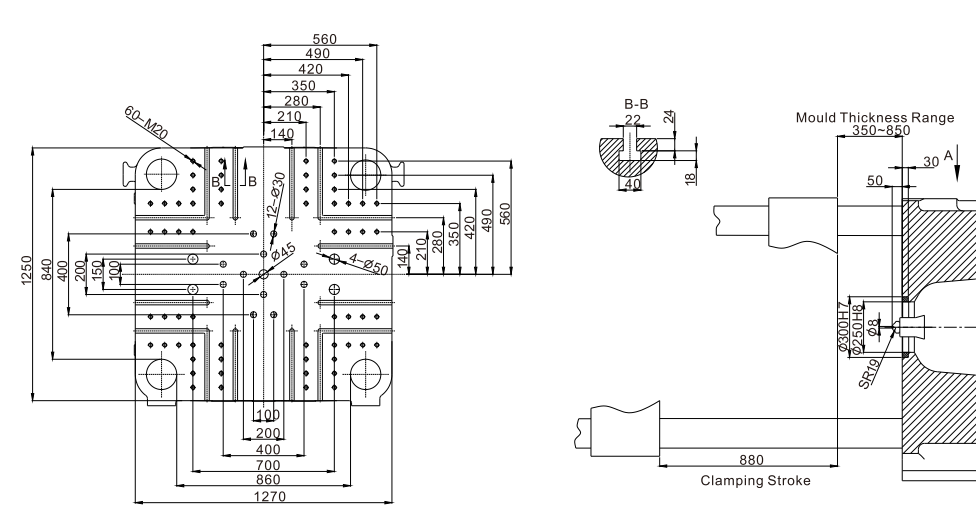

hole pattern for robot/sprue picker on fixed platen (Euomap 18-E13)

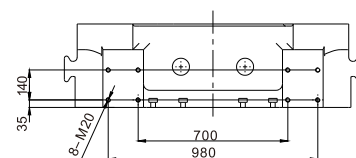

660PVC-KII

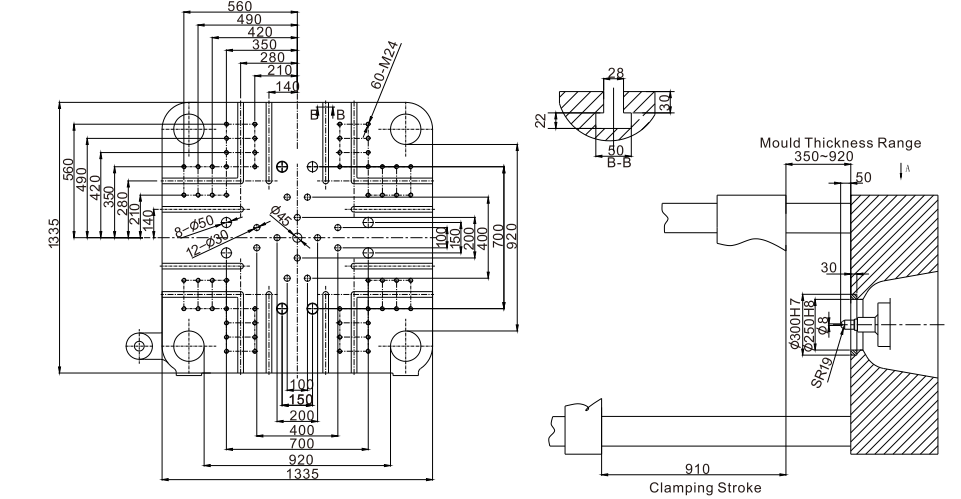

hole pattern for robot/sprue picker on fixed platen (Euomap 18-E15)

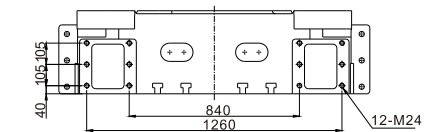

Large-sized PVC servo pump parameters

Item	Unit	750 PVC-SeIII	850 PVC-SeIII	1000 PVC-SeIII	1250 PVC-SeIII	1500 PVC-SeIII	1800 PVC-SeIII
<b>Injection Unit</b>							
Screw diameter	mm	100	100	110	125	135	145
Theoretical shot volume	cc	3691	3691	4657	6835	9232	10651
Shot weight (PVC)	g	4430	4430	5588	8203	11079	12781
Shot weight (PVC)	oz	157	157	197	290	391	452
Injection pressure	MPa	171	171	173	180	187	162
Injection rate	cm <sup>3</sup> /sec	706	706	787	839	810	1215
Injection stroke	mm	470	470	490	557	645	645
Max. screwspeed	rpm	0-81	0-81	0-71	0-60	0-46	0-47
Injection unit force	Ton	19.8	19.8	19.8	19.8	28.8	28.8
Carriage stroke	mm	600	600	650	800	800	850
<b>Clamping Unit</b>							
Clamping force	Ton	750	850	1000	1250	1500	1800
Max. daylight	mm	2050	2200	2300	2600	2900	3000
Clamping stroke	mm	1025	1100	1150	1300	1500	1500
Distance between tie bars	mm	1000x1000	1060x1060	1100x1100	1250x1250	1400x1400	1600x1400
Min. mould dimension	mm	700x700	740x740	780x780	875x875	980x980	1100x980
Mould thickness range	mm	350-1025	450-1100	450-1150	500-1300	600-1400	700-1500
Ejector force	Ton	25	25	25	25	33	33
Ejector stroke	mm	350	350	350	350	350	380
No. of ejector pins	unit	21	21	21	21	33	33
<b>Power Unit</b>							
Max. motor power	kW	67.6	67.6	77.4	91.6	91.6	104.1
System pressure	Mpa	17	17	17	17	17	17
Hydraulic pump capacity	L/min	440	440	495	550	550	715
No. of heating zones	unit	5+1	5+1	5+1	5+1	5+1	5+1
Heating power	kW	48	48	56	72	90	90
Total power	kW	116.6	116.6	134.4	164.6	182.6	195.1
Total current	A	141.7	141.7	163.4	200.1	222.0	237.1
<b>General</b>							
Machine net weight	Ton	40.0	44.0	53.0	71.0	103.0	130.0
Oil filling capacity	L	1500	1500	1600	1600	2000	2000

  

Item	Unit	750 PVC-KII	850 PVC-KII	1000 PVC-KII	1250 PVC-KII	1500 PVC-KII	1800 PVC-KII
Max. motor power	kW	83.8	83.8	94.2	112	112	131.9
Total power	kW	132.8	132.8	151.2	185	203	222.9
Total current	A	161.4	161.4	183.8	224.9	246.7	270.9

We are always working on improvement and reserve the rights to change design and specifications without prior notice

Machine Dimensions

750PVC-SeIII/PVC-KII ~1800PVC-SeIII/PVC-KII

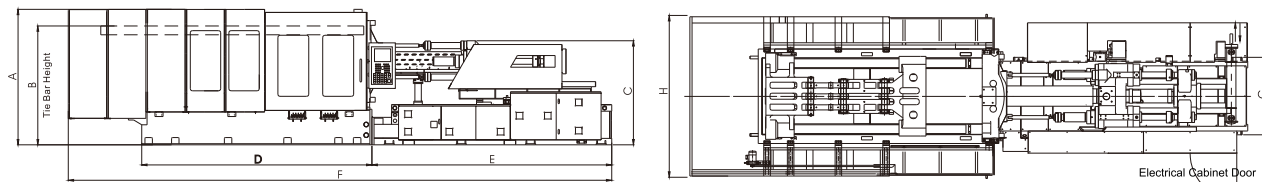

Model	A	B	C	D	E	F	G	H
750PVC-SeIII/PVC-KII	2539	2227	2635	4318	4497	10192	1410	2946
850PVC-SeIII/PVC-KII	2420	2300	2635	4668	4497	10514	1410	3100
1000PVC-SeIII/PVC-KII	2687	2370	2717	4904	4900	11090	1482	3380
1250PVC-SeIII/PVC-KII	2867	2530	2853	5485	5060	12149	1482	3620
1500PVC-SeIII/PVC-KII	2808	2700	3200	6158	5360	13290	1340	4000
1800PVC-SeIII/PVC-KII	2808	2720	3200	6340	5360	13439	1340	4240

Remark: C-hopper height for reference only

Platen/Nozzle Dimensions

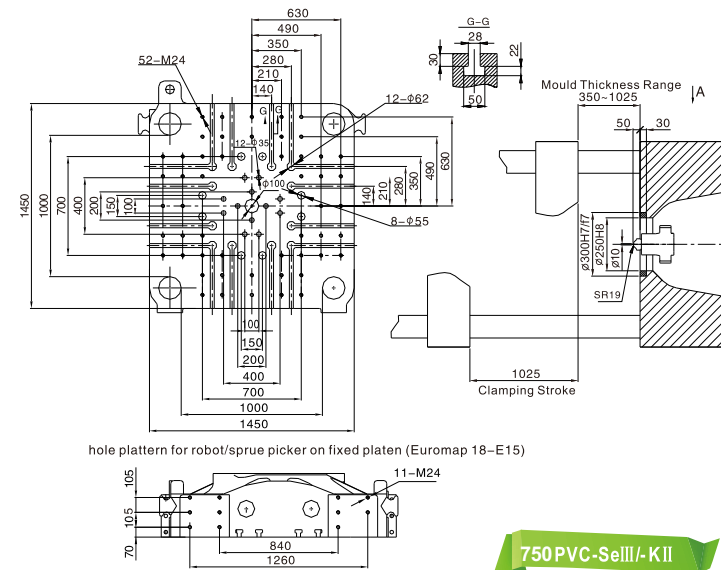

750 PVC-SeIII/-KII

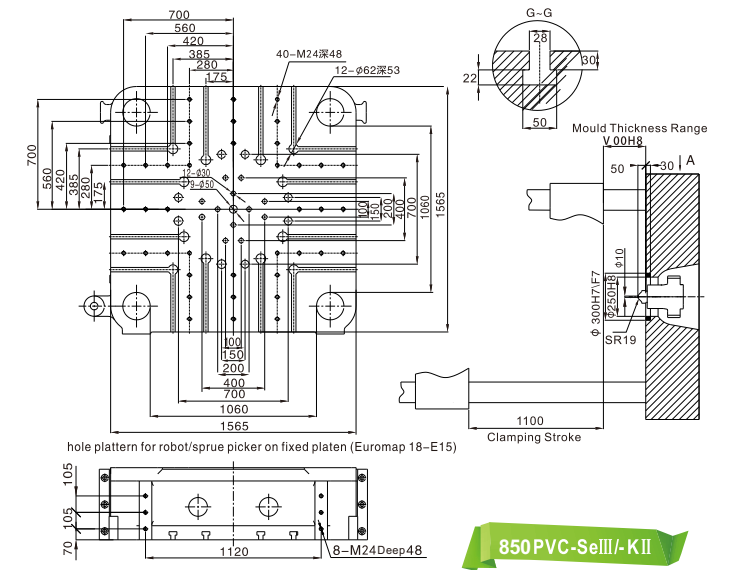

850 PVC-SeIII/-KII

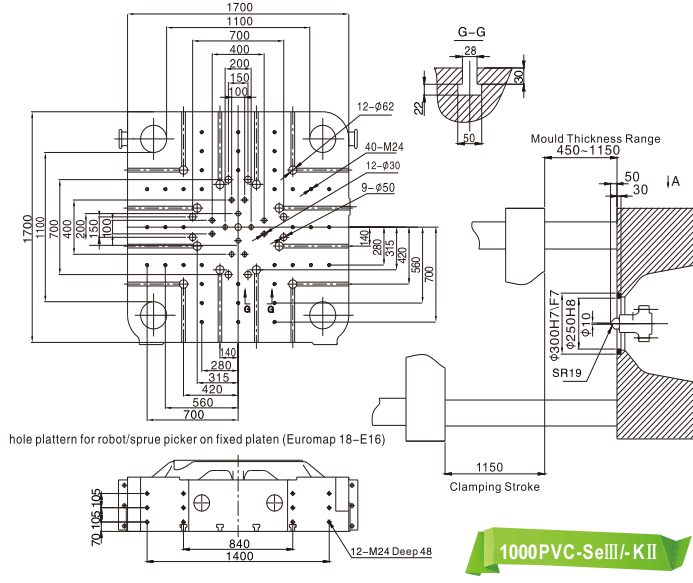

1000 PVC-SeIII/-KII

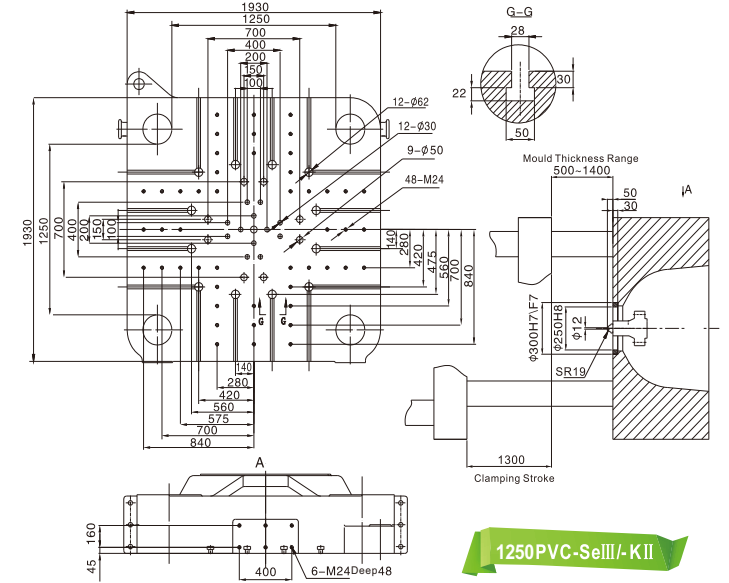

1250 PVC-SeIII/-KII

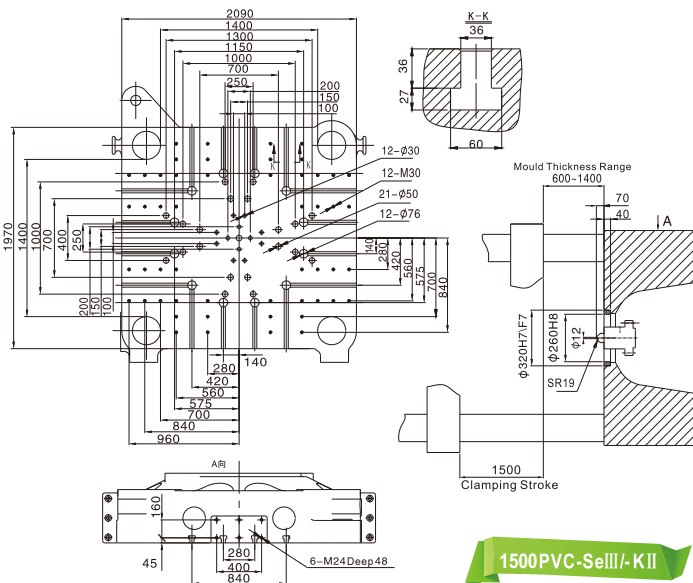

1500 PVC-SeIII/-KII

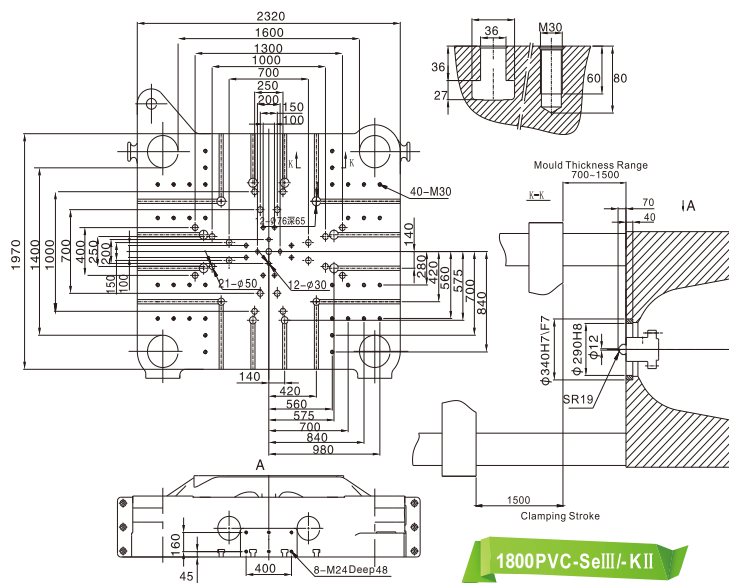

1800 PVC-SeIII/-KII